

Congratulations on purchasing your new Tune product, you made a great choice! We take great care to ensure our products are manufactured to the highest quality standards and that our valued customers have the right guidance to properly maintain their products, helping them last a lifetime. Regular service and maintenance can easily be performed using our Tool-08 kit or any other universal bearing tool kit available on the market, along with a plastic hammer. To prevent damage, never use a metal hammer.

Please find in this guide :

1. Yokto rear disassembly
2. Yokto rear assembly

Bearing chart table :

Hubshell	Drive side	Non drive side
Yokto Front CL (100mm)	1x6803	1x6803
Yokto Rear CL (142mm)	1xMR17287	1x6803
Micro & Nano Front CL (100mm)	1x6803	1x6803
Micro & Nano Rear CL (142mm)	1x6903	1x6803
Micro & Nano Front 6b (110mm)	1x6803	1x6803
Micro & Nano Rear 6b (148mm)	1x6903	1x6803

Freehub	Inside	Outside
HG, XDR, N3W, Microspline	1x6803	1x6803

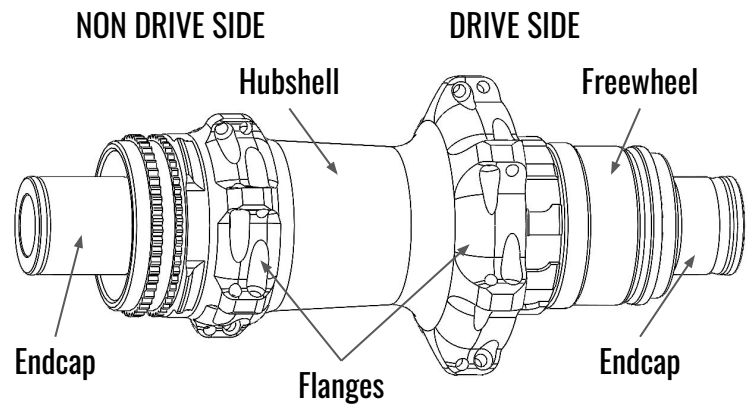

1.1 Endcaps removal

To disassemble your rear hub, you first need to remove the end caps. The end caps are pressed onto the axle with some grease. Use TT08-19, a long flat-head screwdriver, or any other small metal rod through the axle to push against the inner surface of one end cap, and then the other. You can use a hammer or a hard surface to assist with this. Please note that the steps are the same, whether you have an XDR or Hyperglide freewheel.

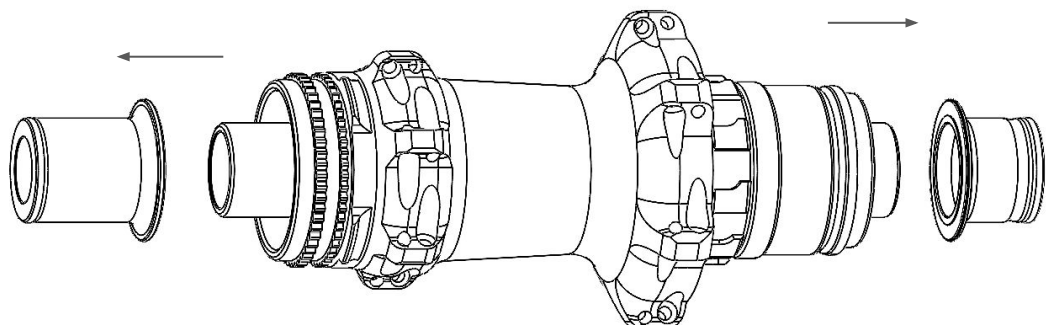
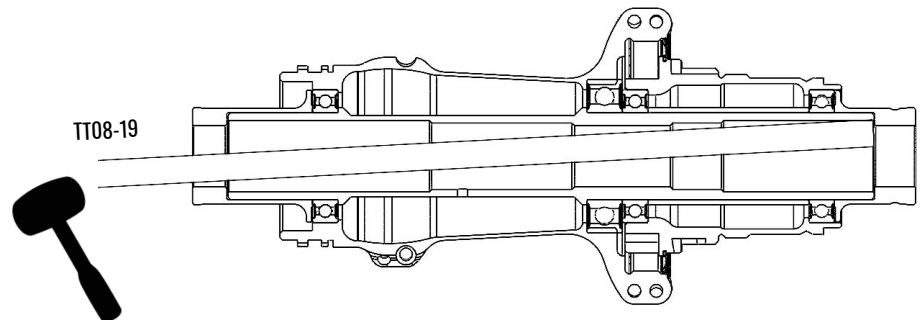

1.2 Freewheel and axle removal

Once the end caps are removed, use TT08-2 and TT08-3 with a hammer to push the axle out from the drive side. This will push both the axle and the non-drive side bearing out from the non-drive side. Once this is done, simply pull the freewheel assembly off with a small counterclockwise rotation. Once the freewheel is removed, you'll find a small washer (20x17x0.2mm*) that should be placed between the drive-side bearing of the hub shell and the inner bearing of the freewheel. Be careful not to lose it.

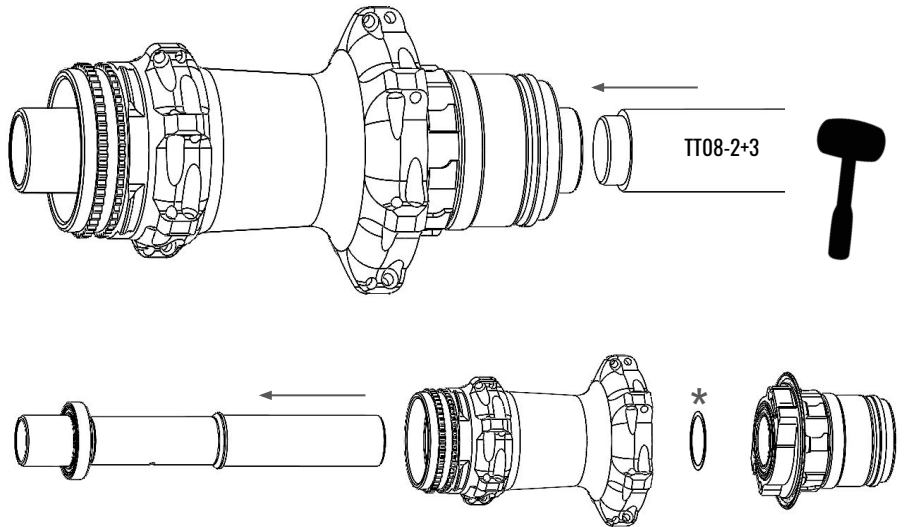

1.3 Bearing removal

Once the axle is removed, you can pull the 6803 bearing out by hand. If you can't remove it by hand, refer to Tech Tips 2 for guidance. After removing the non-drive side bearing, use the axle as a tool to remove the drive-side bearing. Insert the axle back through the hub from the non-drive side and use a plastic hammer to gently push the axle and bearing out. Once the bearing is out, you can either remove it by hand or simply follow the same steps from Tech Tips 2 for the non-drive side bearing.

Tech tips 1 : To prevent any damages, only remove your bearing if they need to be replaced

Tech tips 2 : Tap your axle upside down to make the bearing slide on the axle. Once it's at the edge of the axle, just pull hard with your hand

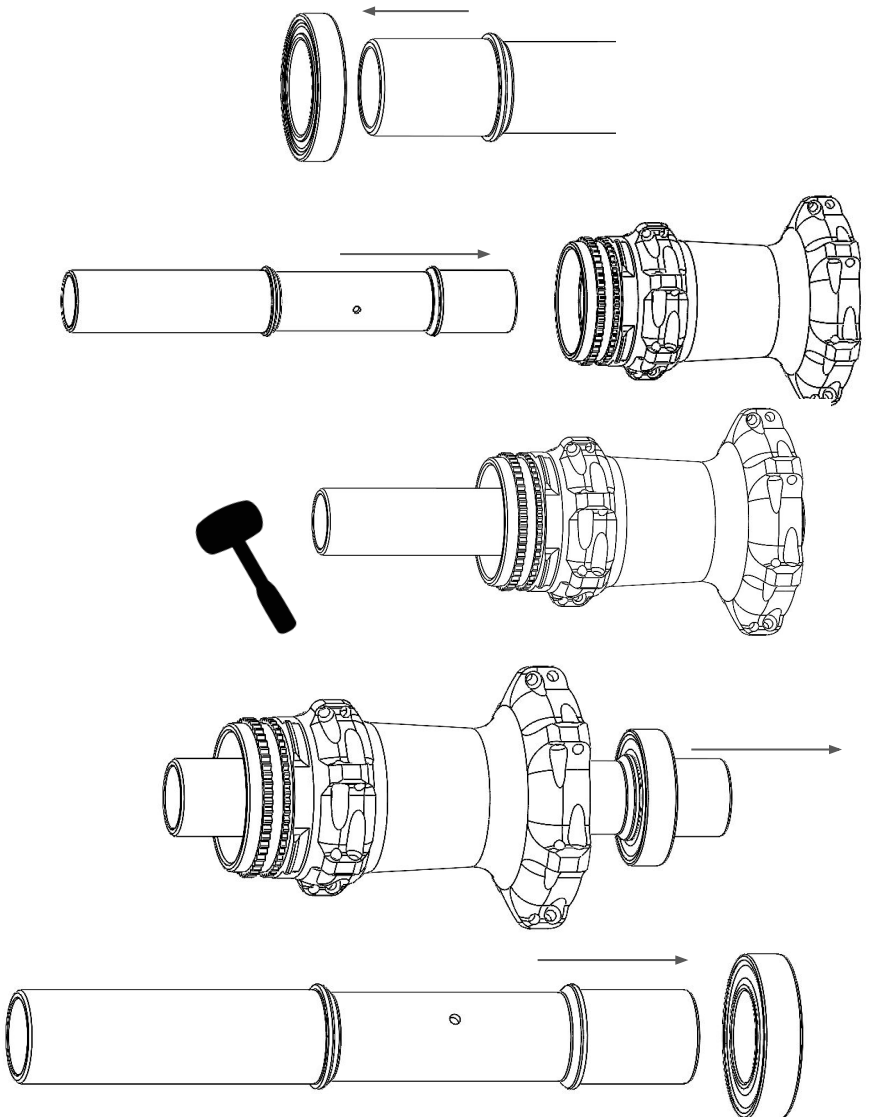
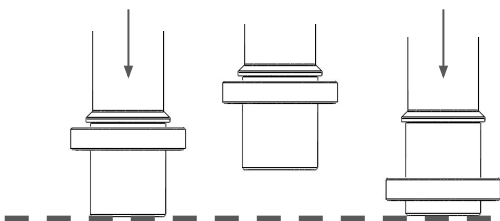

2.1 Axle assembly

To assemble your rear hub, start by assembling the rear axle, the non-drive side bearing, and the non-drive side end cap. Apply a thin layer of grease to the axle, slide the bearing onto the axle, and then use a plastic hammer to gently press the end cap into place.

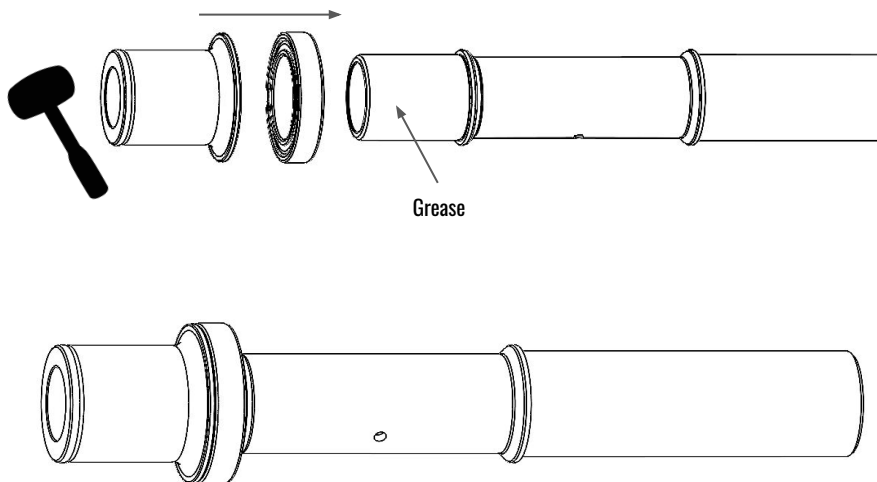

Tech tips 1 : Non drive side end cap is the longest end cap, with no groove and one lip.

Tech tips 2 : XD-15 ceramic bearings do not have a specific side for mounting, unlike ABEC-5 steel bearings.

2.2 Drive side bearing assembly

To prepare the hub shell, start by applying mounting compound or grease to both bearing seats. Once this is done, press the drive-side bearing into the hub shell using TT08-14 or any other compatible bearing tool.

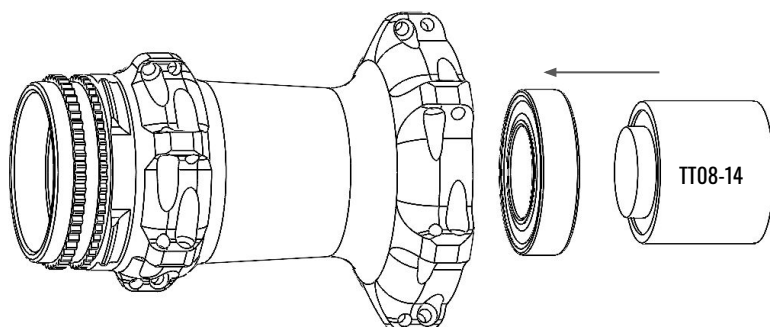

Tech tips : When you press your bearing, always make sure it's correctly aligned. If not, restart the process, and hammer more gently until the bearing is perfectly aligned.

2.3 Hub pre assembly

The Yokto rear hub requires a washer between the drive-side bearing of the hub shell and the inner bearing of the freehub. This washer ensures that the two seals of the bearing, which are close in size, don't touch each other and cause friction. To make the freehub assembly easier, simply push the axle assembly into the hub shell from the non-drive side—just enough to place the washer in the correct position. Do not push the axle in further, as having it fully pushed can make the next assembly steps more difficult.

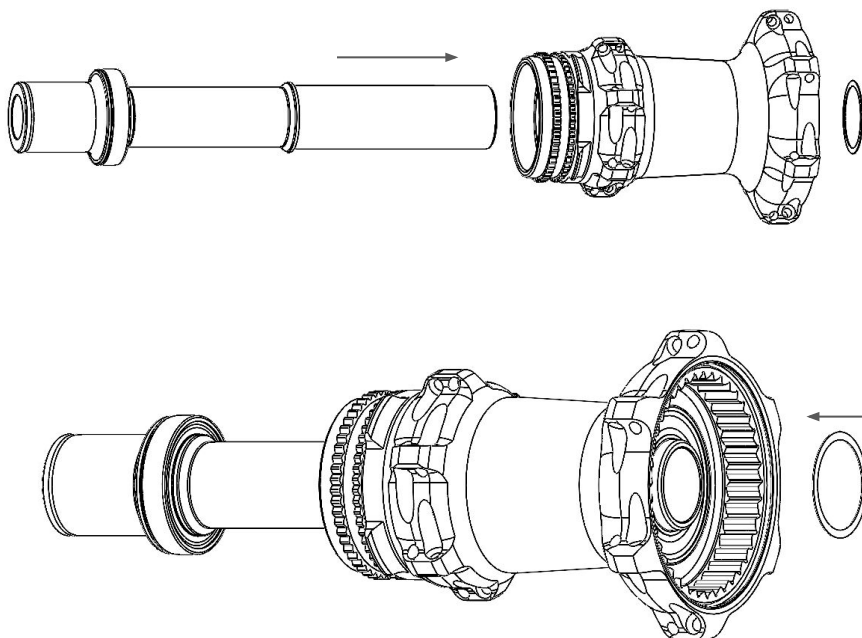

2.4 Toothed ring greasing

To ensure smooth operation of your freewheel system, you must apply grease to the toothed ring. As standard, we recommend using MOLYKOTE Longterm 2 Plus grease. Apply a generous amount of grease to different areas of the toothed ring, as shown in the drawing.

Tech tips :

- Not using any grease can cause serious wear
- Using too much grease can cause malfunctions, always check if the hub is working properly before riding
- Want to make your hub more silent? We can recommend DUMOND tech pro x freehub grease

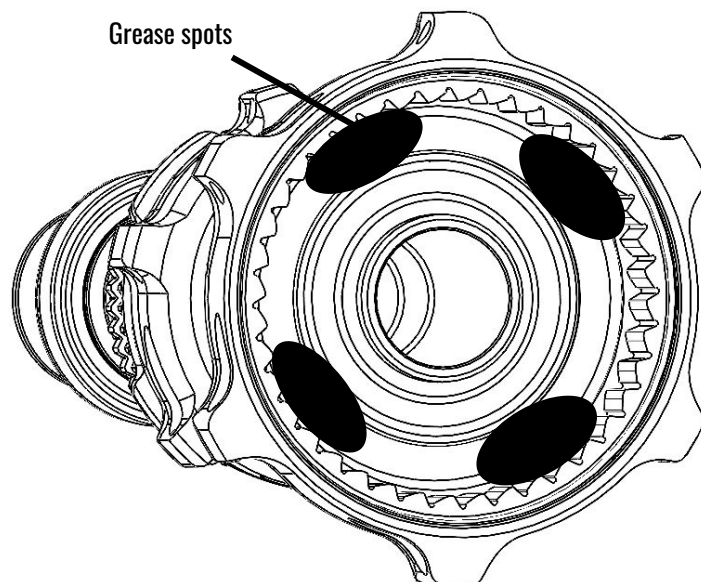

2.5 Freewheel assembly

Once the toothed ring is properly greased, install the freewheel onto the previous assembly. Installing it at a slight angle and turning it counterclockwise about half a turn will help engage the pawls into the toothed ring more easily.

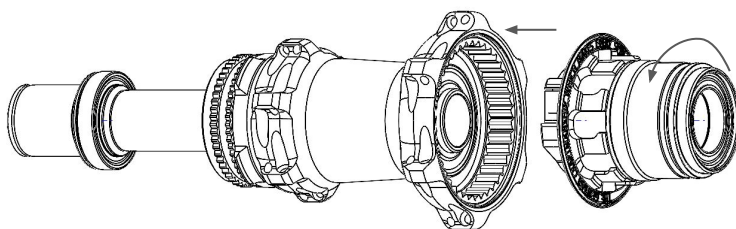

2.6 Final assembly

To finalize the assembly of the rear hub, first make sure that the sleeve of the freewheel is centered. Then you'll have to put the drive side endcap on the freewheel and place the whole assembly on a workbench or any other hard surface. Apply a bit of grease in the endcap. The assembly has to be placed so that the drive side endcap is on the surface, and the axle is upward.

Then firmly push the axle assembly through the hubshell, the freewheel and the drive side endcap.

Once assembled, check if the axle spins smoothly, and if the freehub is working properly.

Tech tips : If you feel some slight resistance or hard spot while spinning the axle, use a plastic hammer to gently hit the endcaps, the freehub body and the flanges. This will allow everything to seat properly.

