

Congratulations on purchasing your new Tune product, you made a great choice! We take great care to ensure our products are manufactured to the highest quality standards and that our valued customers have the right guidance to properly maintain their products, helping them last a lifetime. Regular service and maintenance can easily be performed using our Tool-08 kit or any other universal bearing tool kit available on the market, along with a plastic hammer. To prevent damage, never use a metal hammer.

Please find in this guide :

1. Yokto front disassembly
2. Yokto front assembly

Bearing chart table :

Hubshell	Drive side	Non drive side
Yokto Front CL (100mm)	1x6803	1x6803
Yokto Rear CL (142mm)	1xMR17287	1x6803
Micro & Nano Front CL (100mm)	1x6803	1x6803
Micro & Nano Rear CL (142mm)	1x6903	1x6803
Micro & Nano Front 6b (110mm)	1x6803	1x6803
Micro & Nano Rear 6b (148mm)	1x6903	1x6803

Freehub	Inside	Outside
HG, XDR, N3W, Microspline	1x6803	1x6803

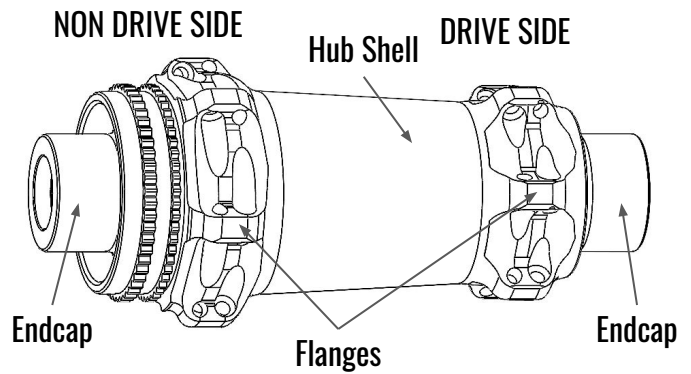

1.1 Endcaps removal

To disassemble your front hub, you first need to remove the end caps. The end caps are pressed onto the axle with some grease. You'll need to use TT08-19, a long flat-head screwdriver, or any other small metal rod through the axle to push against the inner surface of one end cap, and then the other. Use a plastic hammer or a hard surface to apply gentle pressure.

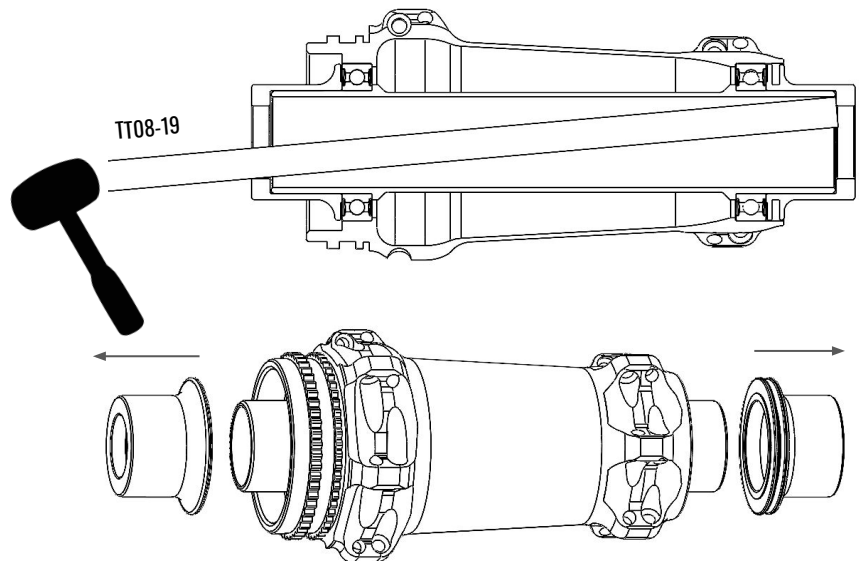

1.2 Axle removal

Once the end caps are removed, use TT08-2 and TT08-3 with a plastic hammer to push the axle out from the drive side. This will push the axle and the non-drive side bearing out through the non-drive side.

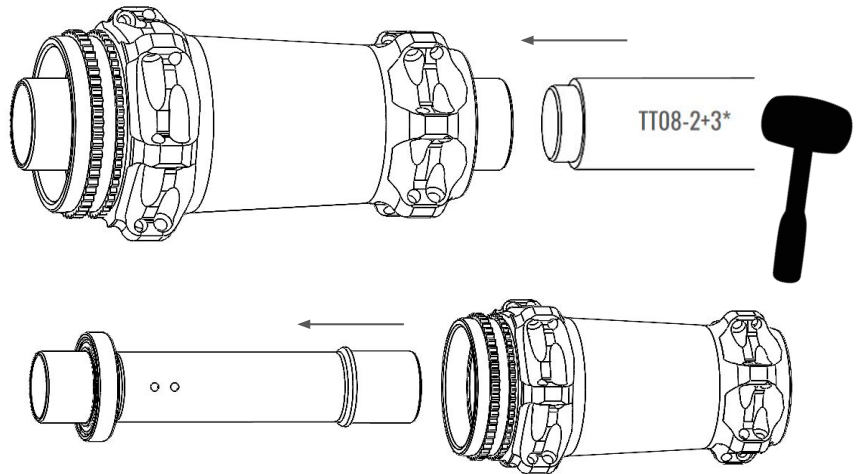

1.3 Bearing removal

Once the axle is removed, you can pull out the 6803 bearing by hand. If you can't remove it by hand, refer to Tech Tips 2 for assistance.

After removing the non-drive side bearing, use the axle as a tool to remove the drive-side bearing. Insert the axle back through the hub from the non-drive side and use a plastic hammer to push the axle and bearing out. Once removed, simply repeat the same steps as for the non-drive side bearing.

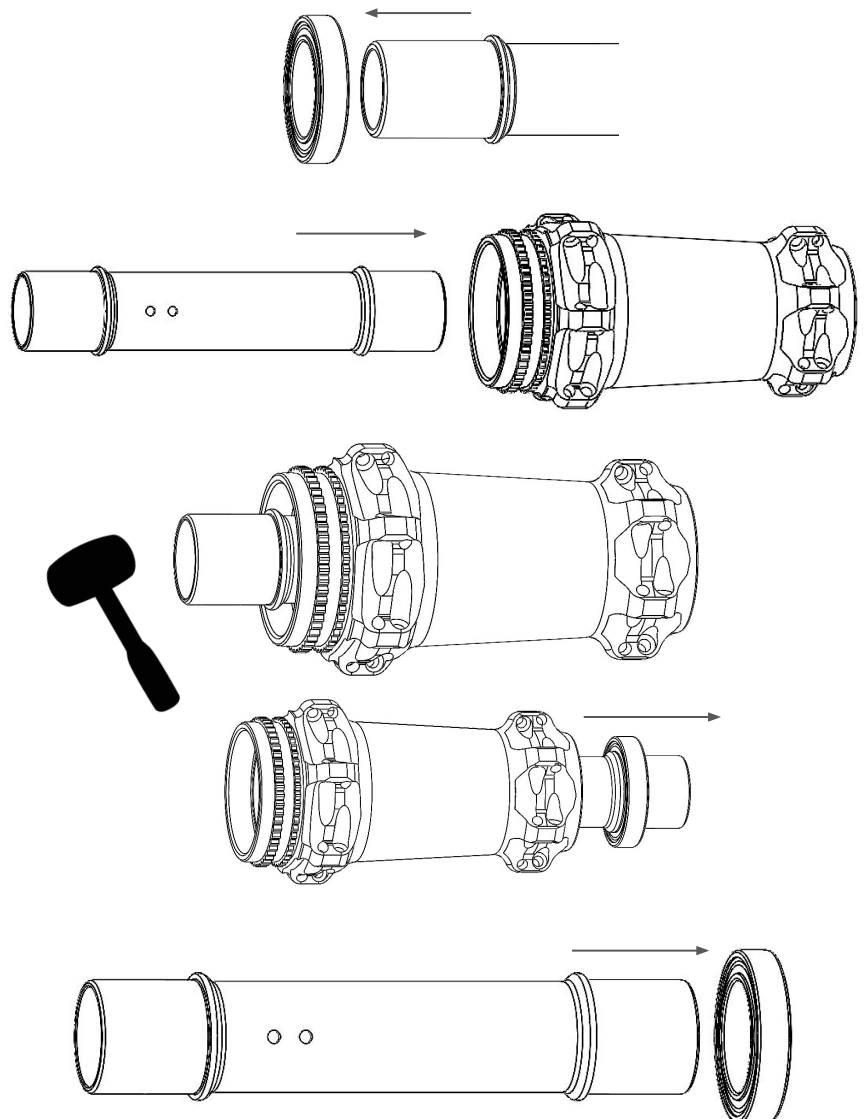

Tech tips 1 : To prevent any damages, only remove your bearing if they need to be replaced

Tech tips 2 : Tap your axle upside down to make the bearing slide on the axle. Once it's at the edge of the axle, just pull hard with your hand

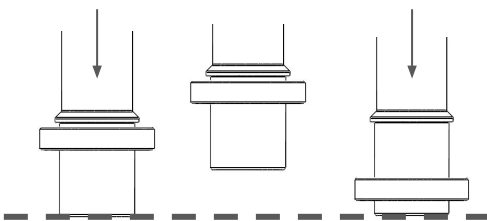

2.1 Axle assembly

To assemble your front hub, start by assembling the front axle, the non-drive side bearing, and the non-drive side end cap. Apply a thin layer of grease to the axle, slide on the bearing, and then push the end cap into place using a plastic hammer.

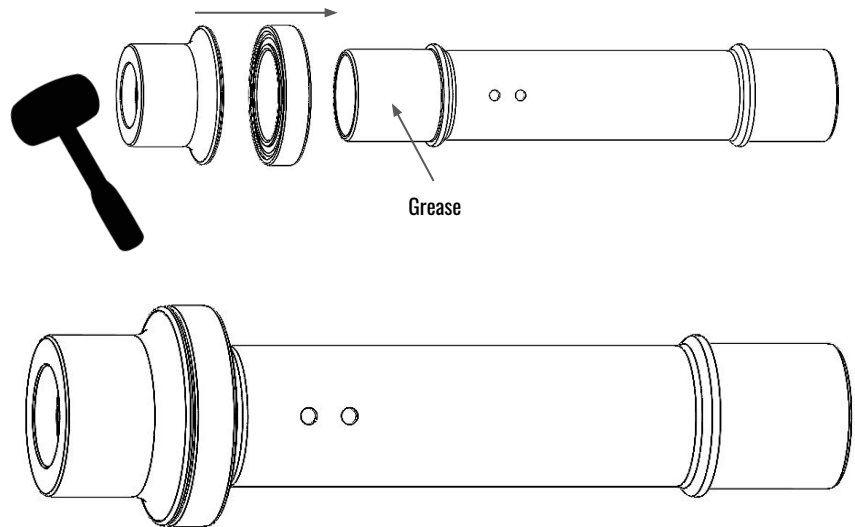

Tech tips 1 : Non drive side end cap is the one with 1 lip. Drive side end cap has 2 lips.

Tech tips 2 : XD-15 ceramic bearings do not have a specific mounting direction, unlike ABEC-5 steel bearings.

Tech tips 3 : On centerlock front hubs, the holes* on the axle (2 for Yokto, 1 for Micro and Nano) must always be placed on the non drive side.

NON DRIVE SIDE

DRIVE SIDE



2.2 Drive side bearing assembly

To prepare the hub shell, start by applying some mounting compound or grease to both bearing seats. Once this is done, press the drive-side bearing into the hub shell using TT08-14 or any other compatible bearing tool.

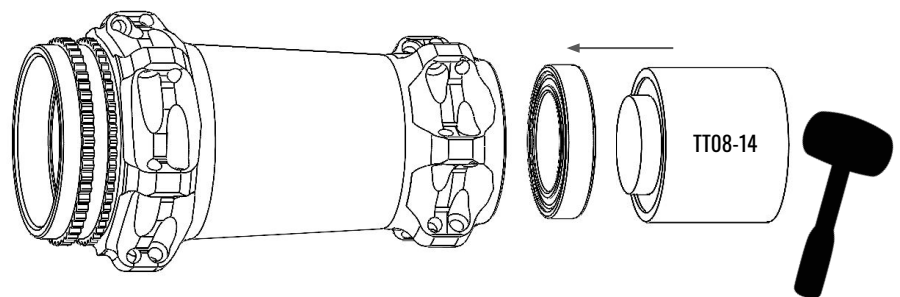

Tech tips : When you press your bearing, always make sure it's correctly aligned. If not, restart the process, and hammer more gently until the bearing is perfectly aligned.

2.6 Final assembly

To complete the assembly of the front hub, start by applying a small amount of grease inside the drive-side end cap. Place the drive-side end cap against the drive-side bearing and position the entire assembly on a workbench or any other hard surface. Next, insert the axle assembly through the hub shell. Ensure the assembly is positioned with the drive-side end cap resting on the surface and the axle pointing upward. Use a plastic hammer to gently push the axle assembly through the drive-side bearing and the drive-side end cap. Once assembled, check that the axle spins smoothly and verify that the hub is functioning correctly.

Tech tips 1 : If you feel some slight resistance or hard spot while spinning the axle, use a plastic hammer to gently hit the endcaps, the freehub body and the flanges. This will allow everything to seat properly.

Tech tips 2 : Drive side endcap is the one with two lips.

