

Congratulations on purchasing your new Tune product, you made a great choice! We take great care to ensure our products are manufactured to the highest quality standards and that our valued customers have the right guidance to properly maintain their products, helping them last a lifetime. Regular service and maintenance can easily be performed using our Tool-08 kit or any other universal bearing tool kit available on the market, along with a plastic hammer. To prevent damage, never use a metal hammer.

Please find in this guide :

1. Freewheel change
2. Freewheel disassembly
3. Freewheel assembly

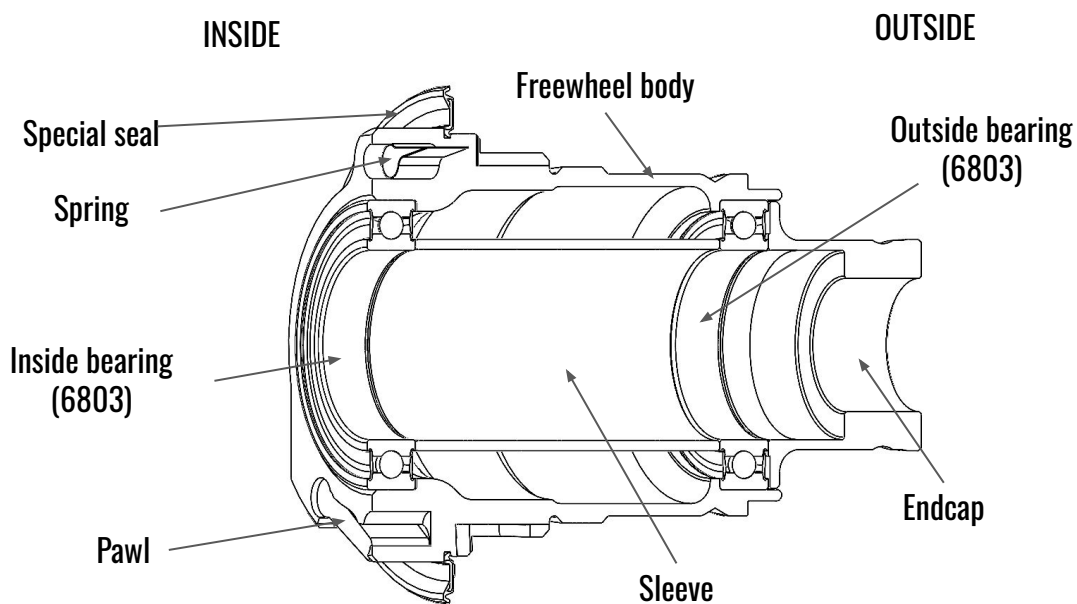

## 1.1 Freewheel swap, removal

The following steps explain how to change an XDR freewheel to an Hyperglide freewheel. If you wish to install an XDR freewheel instead of an original Hyperglide freewheel, the steps are exactly the same. To change your freewheel, you will first need to remove the drive-side end cap. The end cap is pressed onto the axle with some grease. You'll need to use TT08-19, a long flat screwdriver, or any other small metal rod through the axle to push against the inner surface of the end cap. Use a hammer or a hard surface to assist with this.

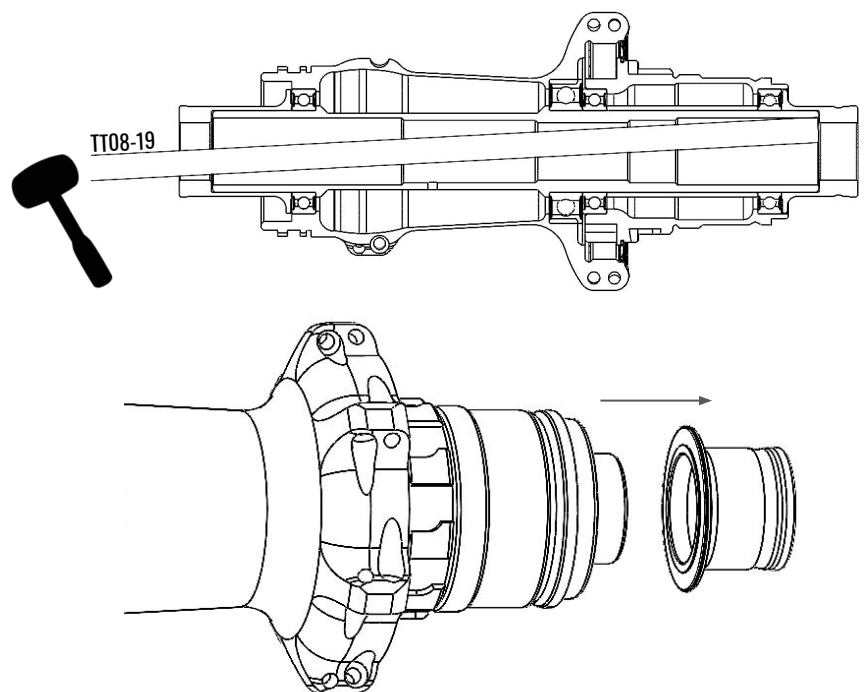

### 1.2 Axle & freewheel removal

Once the drive-side end cap is removed, use TT08-2 and TT08-3 along with a plastic hammer (or any other compatible bearing tool kit) to push the axle until you feel the freewheel assembly moving. Removing the axle completely is not necessary to change the freewheel. Next, simply pull the freewheel assembly and give it a half counterclockwise spin to remove it from the hub assembly.

**CAUTION :** To prevent the bearing seals from touching, there is a 20x17x0.2mm washer between the drive-side bearing of the hub shell and the inner bearing of the freewheel body. Be careful not to lose it. It must be reinstalled between these bearings.

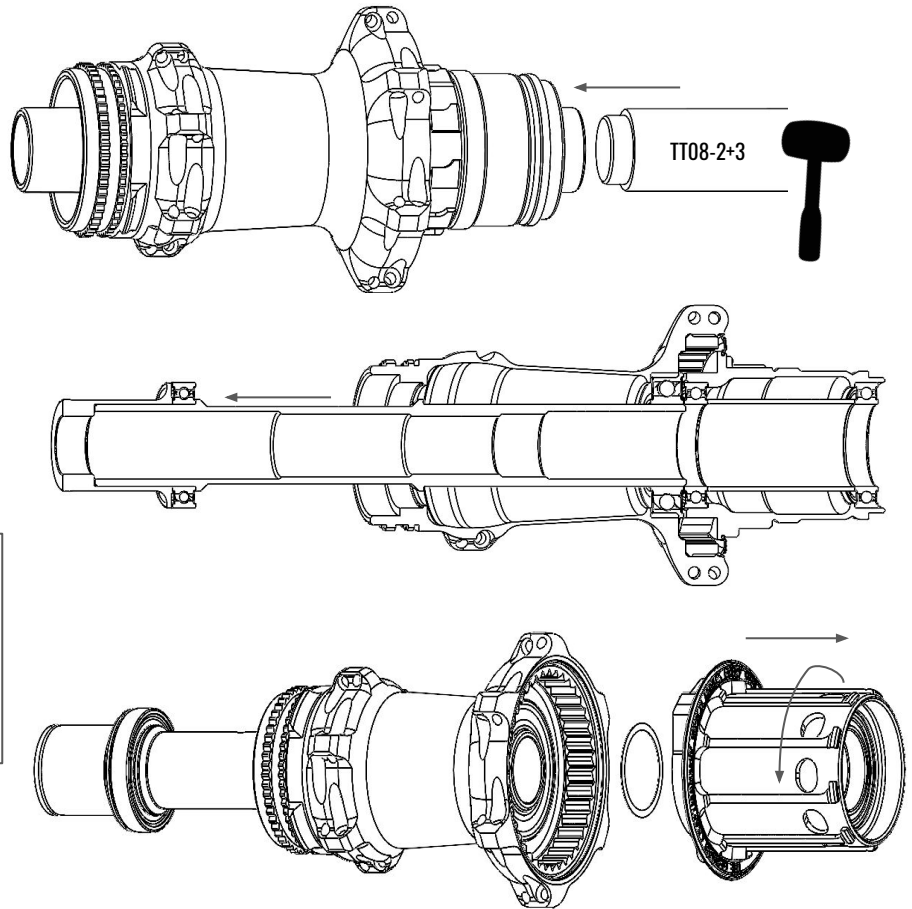

### 1.3 Clean and grease

Once the freewheel is removed, take off the 20x17x0.2mm washer and clean the toothed ring of any dust or dirt if necessary. Once clean, apply grease to the toothed ring. As standard, we recommend using MOLYKOTE Longterm 2 Plus grease. Apply a generous amount of grease to different areas of the toothed ring, as shown in the drawing.

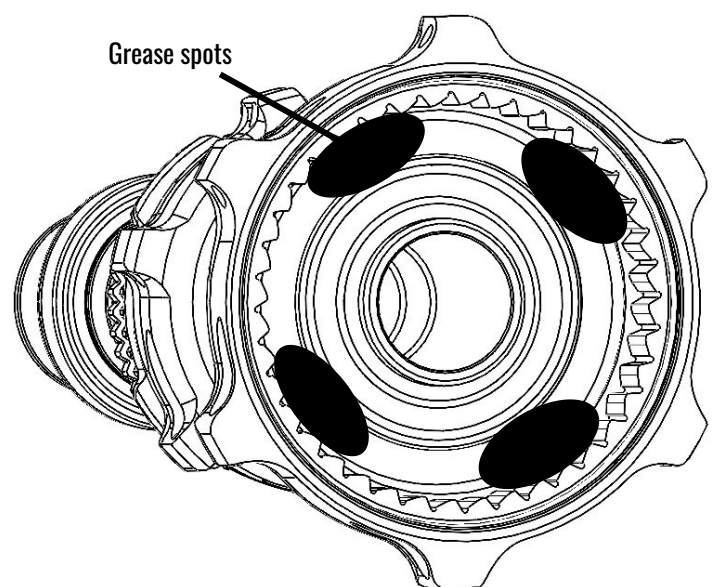

#### Tech tips :

- Not using any grease can cause serious wear
- Using too much grease can cause malfunctions, always check if the hub is working properly before riding
- Want to make your hub more silent? We can recommend DUMOND tech pro x freehub grease

### 1.4 New freewheel instal

Place the 20x17x0.2mm washer on the tip of the axle on the hub assembly before installing the new freewheel assembly. Perform the same counterclockwise half-turn you did in the second step. This will help the pawl engage with the toothed ring.

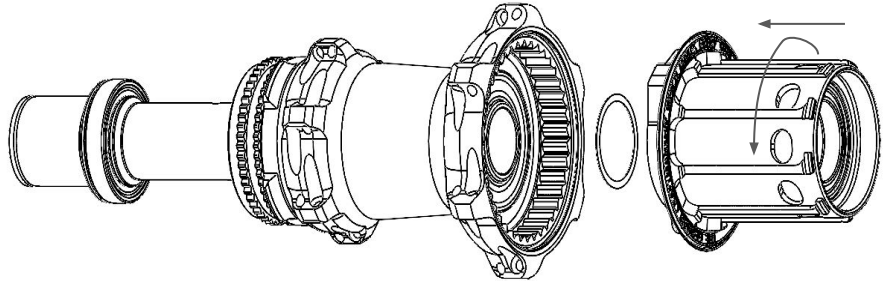

### 1.5 Final assembly

To finalize the assembly of the rear hub, first make sure the inner sleeve of the freewheel body is centered. Apply a bit of grease to the drive-side end cap. Then, place the drive-side end cap onto the freewheel and position the entire assembly on a workbench or any other hard surface.

The assembly should be positioned so that the drive-side end cap is resting on the surface and the axle is pointing upward.

Next, firmly push the axle assembly through the hub shell, the freehub, and the drive-side end cap.

Once assembled, check that the axle spins smoothly and that the freehub is functioning properly.

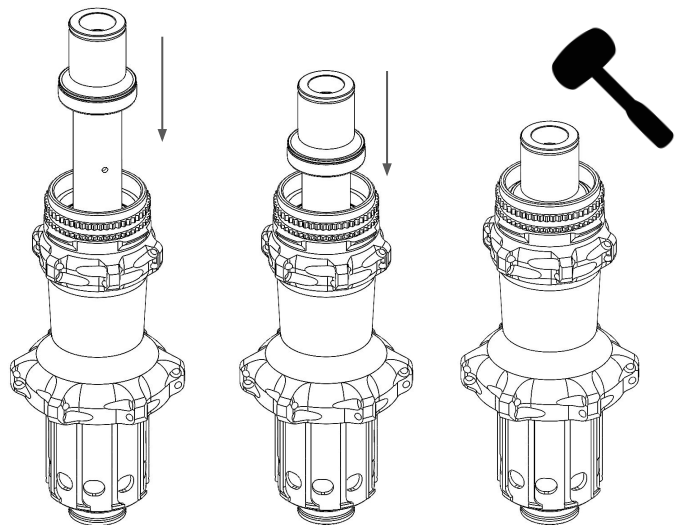
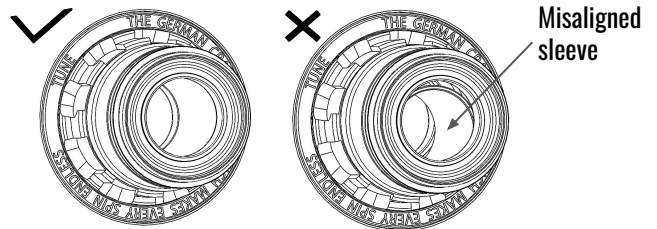

**Tech tips :** If you feel some slight resistance or hard spot while spinning the axle, use a plastic hammer to gently hit the endcaps, the freehub body and the flanges. This will allow everything to seat properly.

### 2.1 Freewheel disassembly

To disassemble your freewheel, first remove the special seal to prevent any damage during the next steps. The special seal is a rubber ring with a steel core. If it becomes bent, you can straighten it by gently bending it in the opposite direction.

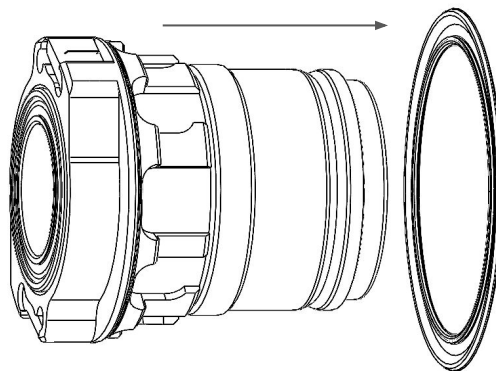

### 2.1 Pawls and springs removal

Next, simply remove the pawls and springs by pulling them out of the freewheel assembly.

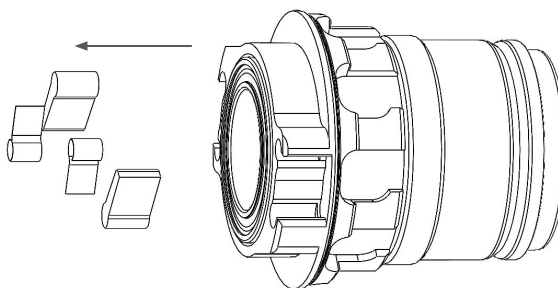

### 2.2 Inside bearing removal

Next, misalign the sleeve and push the inner bearing out using TT08-19. To make this easier, don't hesitate to move the sleeve and push in different spots on the bearing to ensure it comes out straight from the bearing seat. You can place the freewheel on TT08-7 to help with this. Afterward, remove the sleeve.

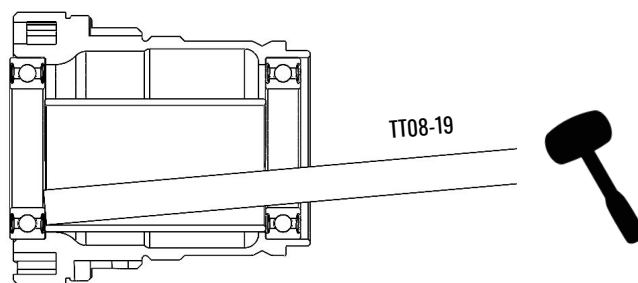

### 2.3 Outside bearing removal

Once the inner bearing and the sleeve are removed, place the freewheel on TT08-7, insert TT08-15 inside, and use TT08-4 to push the outer bearing out of the freewheel body.

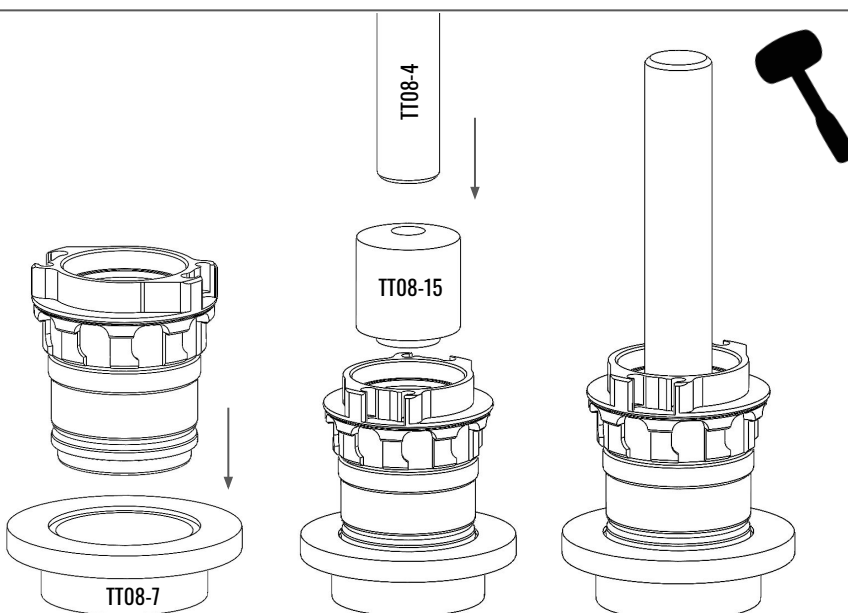

### 3.1 Assembly, inside bearing

Apply grease to both bearing seats. To reassemble your freewheel, begin by pressing the inner bearing of the freehub body using TT08-14 and a plastic hammer. Make sure the bearing stays straight during installation.

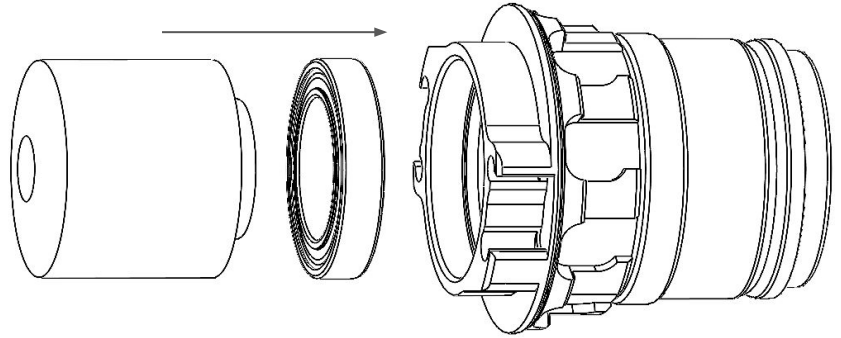

### 3.2 Spacer and outside bearing assembly

Place the freehub assembly on a flat surface, then insert the sleeve and press the outer bearing using TT08-14 and a plastic hammer. Try to keep the sleeve centered so that axle insertion will be easier when you place it on the hub. Be sure that the bearing stays straight during installation.

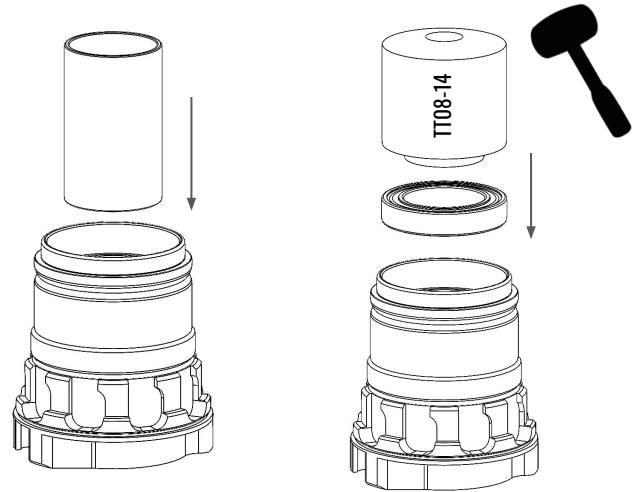

### 3.3 Pawls and springs install

Clean the pawls and springs. Apply some grease to the pawl seats on the freehub. Then, install the springs as shown. Once that's done, install the pawls (with the sharp edge on top) as shown. You'll need to push down the spring with a small screwdriver to properly install the pawls. Check to ensure they are working correctly and moving freely.

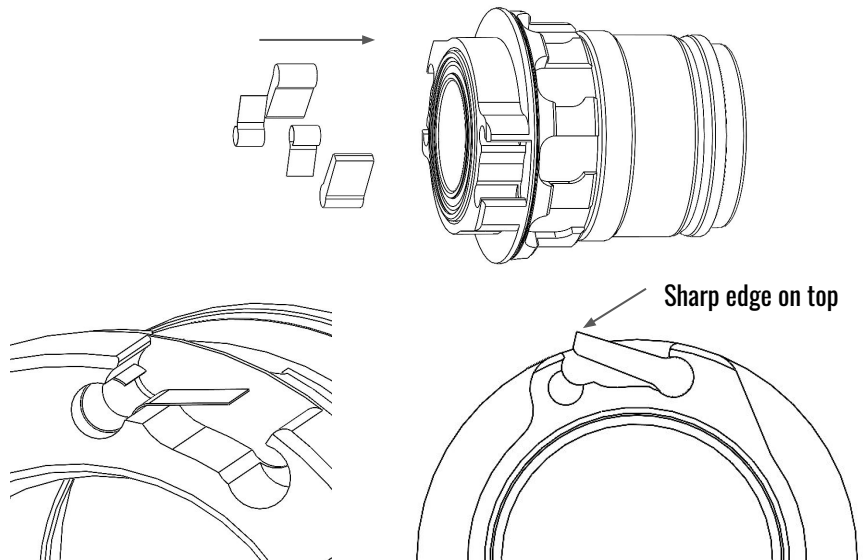

### 3.4 Special seal install

Finally, clean the seal and check if it's damaged. Then, install it the same way you removed it in the first step. Ensure it sits correctly in the groove and is completely straight. Done!

